

PARALLEL ACCESS 64K (8K x 8) EEPROM

DATA BRIEFING

- FAST ACCESS TIME: 150ns
- SINGLE 5V ± 10% SUPPLY VOLTAGE
- LOW POWER CONSUMPTION
- FAST WRITE CYCLE
 - 32 Bytes Page Write Operation
 - Byte or Page Write Cycle: 5ms
- ENHANCED END OF WRITE DETECTION
 - Ready/Busy Open Drain Output (for M28C64C product only)
 - Data Polling
 - Toggle Bit
- PAGE LOAD TIMER STATUS BIT
- HIGH RELIABILITY SINGLE POLYSILICON, CMOS TECHNOLOGY
 - Endurance >100,000 Erase/Write Cycles
 - Data Retention >40 Years
- JEDEC APPROVED BYTEWIDE PIN OUT

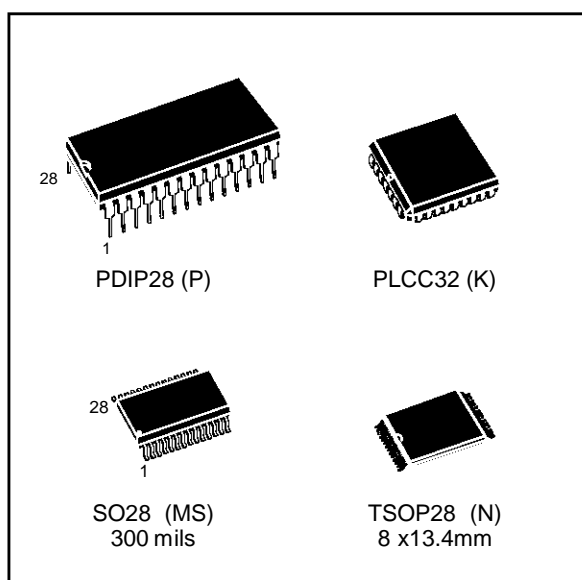

DESCRIPTION

The M28C64C is an 8K x 8 low power Parallel EEPROM fabricated with SGS-THOMSON proprietary single polysilicon CMOS technology. The device offers fast access time with low power dissipation and requires a 5V power supply.

The circuit has been designed to offer a flexible microcontroller interface featuring both hardware and software handshaking mode with Ready/Busy, Data Polling and Toggle Bit. The M28C64C supports 32 byte page write operation.

Signal Names

A0 - A12	Address Input
DQ0 - DQ7	Data Input / Output
\bar{W}	Write Enable
\bar{E}	Chip Enable
\bar{G}	Output Enable
$\bar{R}\bar{B}$	Ready / Busy
V _{CC}	Supply Voltage
V _{SS}	Ground

Logic Diagram

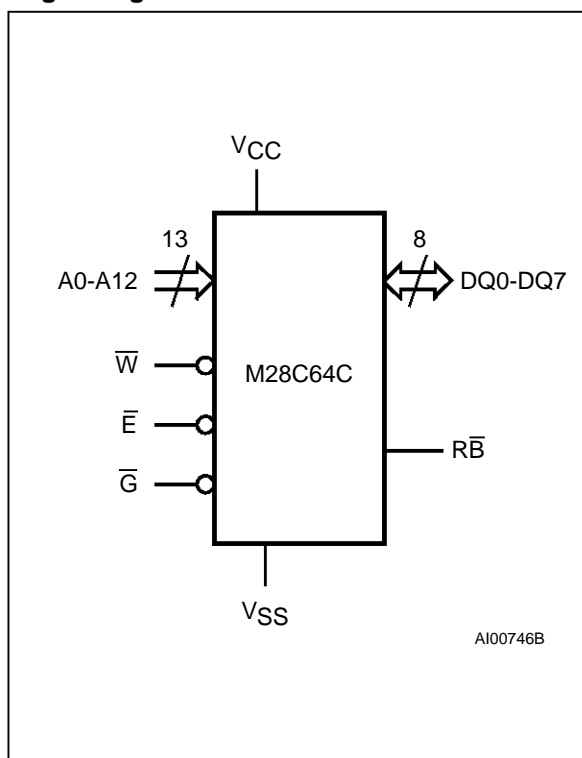

M28C64C, M28C64X

DIP Pin Connections

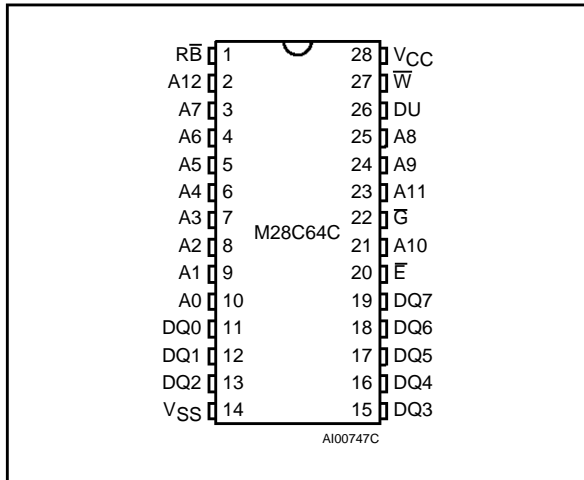

Warning: NC = Not Connected.

TSOP Pin Connections

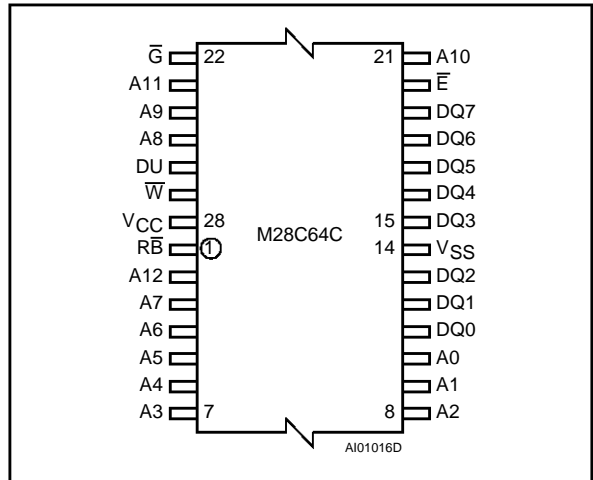

Warning: NC = Not Connected.

LCC Pin Connections

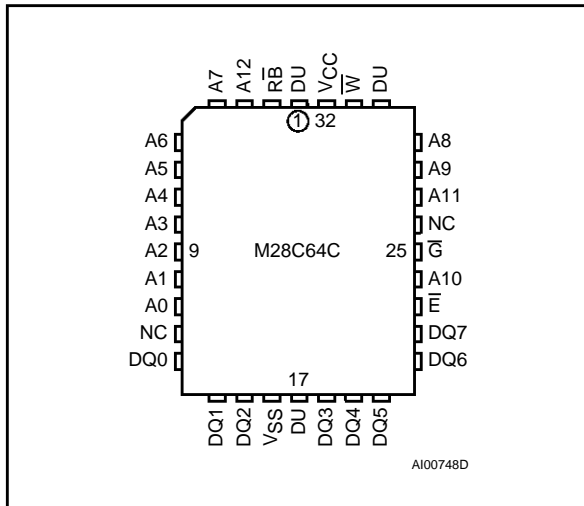

Warning: NC = Not Connected, DU = Don't Use.

SO Pin Connections

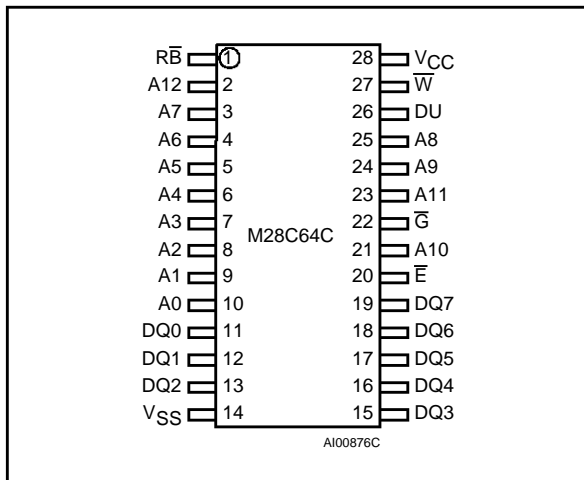

Warning: NC = Not Connected.

Ordering Information Scheme

For a list of available options refer to the current Memory Shortform catalogue. For further information on any aspect of this device, please contact the SGS-THOMSON Sales Office nearest to you.

Example: M28C64C -150 K 1

Version	C	RB available
	X	RB not bonded (pin NC)
Speed	-150	150ns
	-200	200ns
	-250	250ns
Package	P	PDIP28
	K	PLCC32
	MS	SO28 300mils
	N	TSOP28 8 x 13.4mm
Temperature Range	1	0 to 70 °C
	6	-40 to 85 °C